

PARTS BOOK

Weaverline

Models 323 and 330 Battery Powered Carts

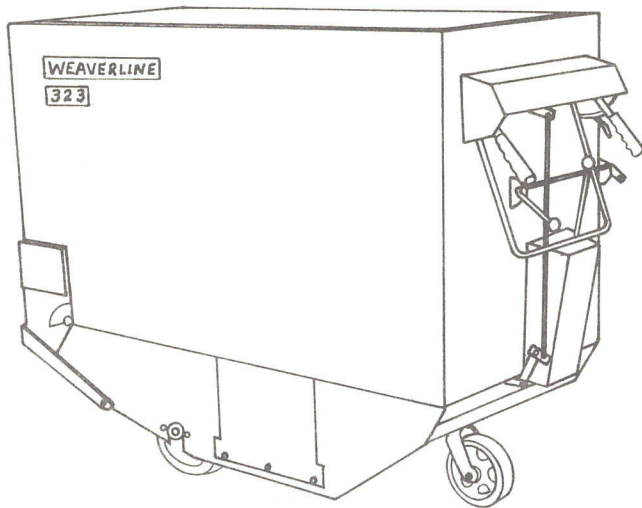

MODEL 323
24 Bushel
Box Length 5 Ft.

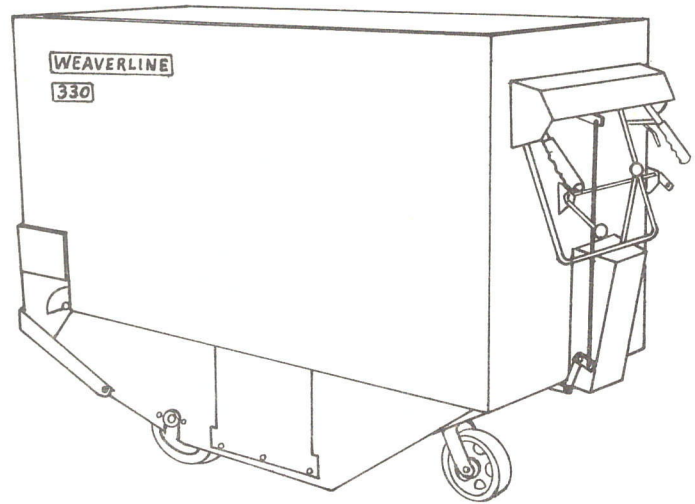







MODEL 330
30 Bushel
Box Length 6 Ft.

IMPORTANT NOTE:

When ordering parts:

- (a) Always give Model and Serial Number.
- (b) Write the complete Part Number as well as the description of the part.
- (c) Left and right are determined when standing at the controls of the Cart.
- (d) The rear of the Cart is the end with the controls.

BOX AND BEATERS

- A  35
- B  36
- D  38
- E  40
-  37
-  37
-  39

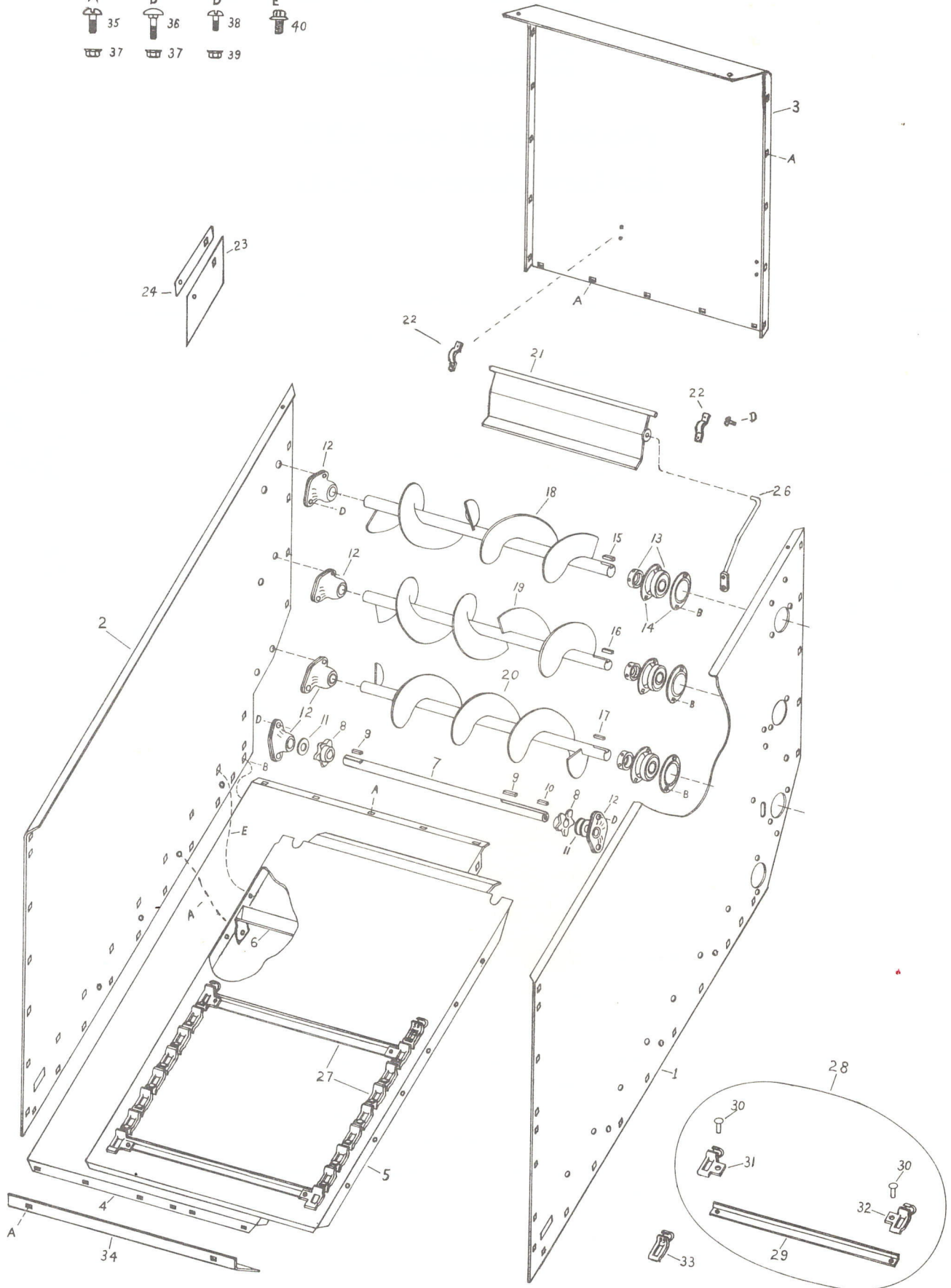

BOX AND BEATERS

Ref. No.	Part No.	Description	Quantity Used	
			323	330
1	202 367 X1	Side Sheet R.H.	1	
1	202 521 X1	Side Sheet R.H.		1
2	202 369 X1	Side Sheet L.H.	1	
2	202 522 X1	Side Sheet L.H.		1
3	303 035	Front Panel	1	1
4	202 368	Main Bottom	1	
4	202 511	Main Bottom		1
5	303 046	False Botom Replacement Kit	1	
5	303 031 X2	False Botom Replacement Kit		1
6	303 036	Support Weld Assembly	3	4
7	202 379	Apron Drive Shaft	1	
7	202 721	Apron Drive Shaft		1
8	202 756	Apron Drive Sprocket	2	2
9	69 007	Key 1/4 sq. x 1 3/8	2	2
10	69 008	Key 1/4 sq. x 3/4	1	1
11	202 889	Washer 1 1/2 x 1 x 18 ga.	3	3
12	202 914	Bearing Unit 1"	5	5
13	202 915	Ball Bearing with Collar 1"	3	3
14	202 916	Flangette 2 Hole	6	6
15	69 009	Key 1/4 sq. x 1	1	1
16	69 012	Key 1/4 sq. x 2 3/8	1	1
17	69 011	Key 1/4 sq. x 3	1	1
18	202 771	Auger Weld Ass'y, Top	1	1
19	202 770	Auger Weld Ass'y, next to Top	1	1
20	202 529	Auger Weld Ass'y, third from Top	1	1
21	303 037	Loading Baffle Weld Ass'y	1	1
22	303 010	Baffle Bracket	2	2
23	303 012	Deflector	1	1
24	303 011	Deflector Bracket	1	1
26	303 038	Baffle Arm Weld Ass'y	1	1
27	202 822	Conveyor Ass'y Complete	1	
27	202 501	Conveyor Ass'y Complete		1
28	202 977	Conveyor Slat and Link Ass'y	9	11
29	202 781	Conveyor Slat	9	11
30	62 005	Truss Hd. Rivet 1/4 x 1/2	18	22
31	202 968	Attachment Link L.H. (55 AIL)	9	11
32	202 969	Attachment Link R.H. (55 AIR)	9	11
33	202 970	Plain Link #55	108	134
34	202 565	Corner Baffle	1	1
35	63 016	Truss Hd. Whiz Screw 5/16 NC x 1/2	AR	AR
36	63 009	Carr. Bolt 5/16 NC x 3/4	AR	AR
37	63 010	Whiz Nut 5/16 NC	AR	AR
38	62 001	Truss Hd. Machine Screw 1/4 NC x 1/2	AR	AR
39	62 002	Whiz Nut 1/4 NC	AR	AR
40	63 026	Bolt 5/16 x 5/8 Self-Tapping Special	12	16

FEEDER DRIVE

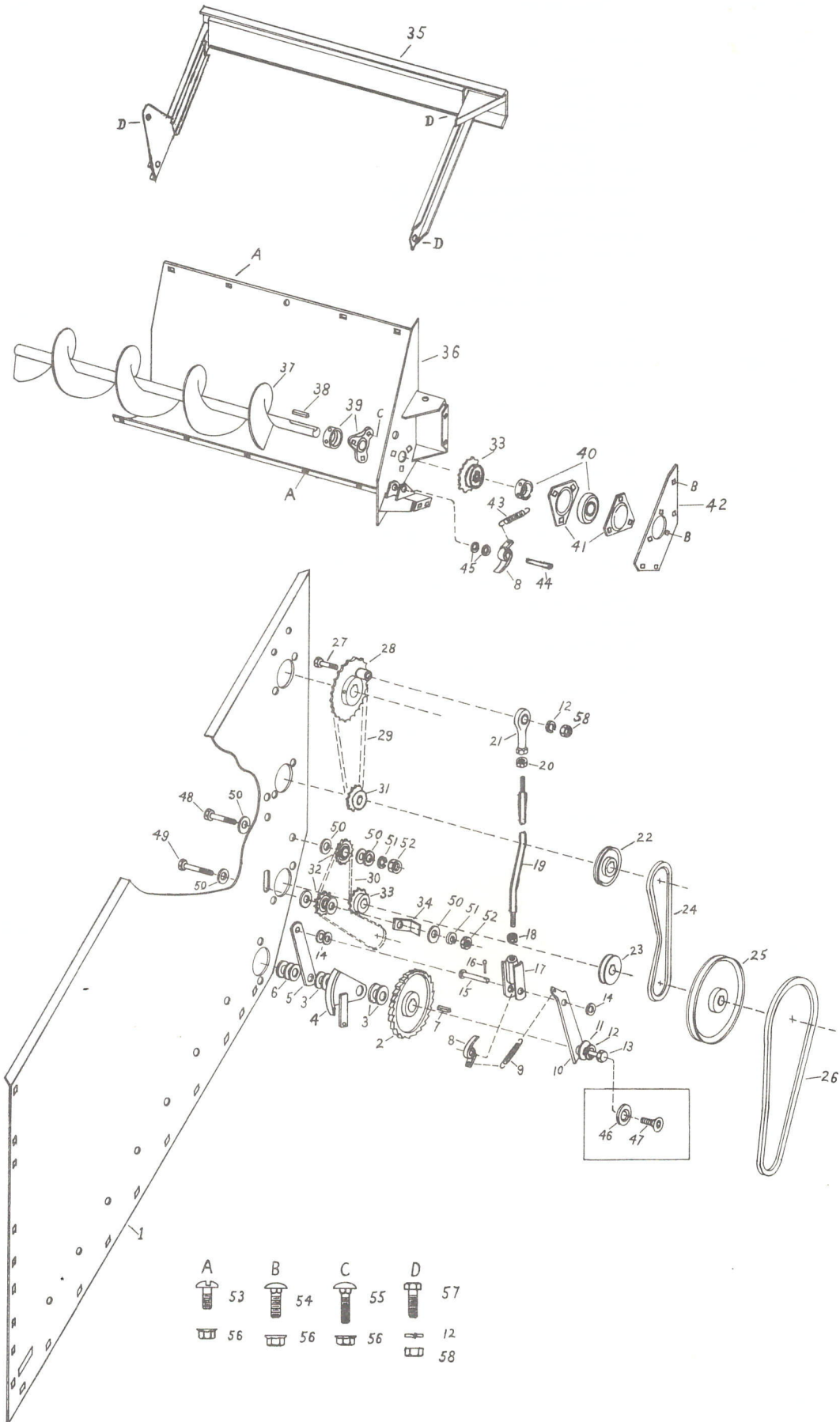

FEEDER DRIVE

Ref. No.	Part No.	Description	Quantity Used	
			323	330
1	202 367 X1	Side Sheet R.H.	1	
1	202 521 X1	Side Sheet R.H.		1
2	202 751	Ratchet	1	1
3	68 002	Washer 1" - 1/32 thick	AR	AR
4	202 727 X1	Cam Weld Ass'y	1	1
5	202 728	Inside Link	1	1
6	68 001	Washer 1" - 1/8 thick	3	3
7	69 008	Key 1/4 sq. x 3/4	1	1
8	202 476 X2	Pawl	2	2
9	202 932	Spring (Drive Pawl)	1	1
10	202 819 X1	Outside Link	1	1
11	202 518	Washer Special 3/8		1
12	64 006	Lock Washer 3/8	AR	AR
13	64 003	Cap Screw 3/8 NC x 1		1
14	64 005	Washer 3/8 USS	3	3
15	202 888 X2	Clevis Pin 3/8 x 1 7/8 Hardened	1	1
16	61 001	Cotter Pin 1/8 x 3/4	1	1
17	202 986	Conn. Rod Yoke Weld Ass'y	1	1
18	65 008	Half Nut 1/2 NC	1	1
19	202 987	Connecting Rod	1	1
20	64 007	Nut 3/8 NF	1	1
21	202 911	Rod End Bearing	1	1
22	202 905	Sheave 4 1/2 O.D.	1	1
23	202 904	Sheave 3 1/4 O.D.	1	1
24	202 922	Belt (4L340)	1	1
25	202 446	Sheave 8 1/2 O.D. - 1" Bore	1	1
26	202 407	Belt (4L 470)	1	
26	202 699	Belt (4L 500)		1
27	64 013	Bolt 3/8 NC x 2 1/4	1	1
28	202 562	Sprocket Weld Ass'y 42 Teeth.....	1	1
29	202 840	Chain #40 - 70 Pitches	1	1
30	202 510	Chain #40 - 80 Pitches	1	1
31	202 909	Sprocket 13 Teeth	1	1
32	202 906	Sprocket Ass'y, Idler	2	2
33	202 908	Sprocket 18 Teeth	2	2
34	202 586	Belt Guide	1	1
35	303 039	Bumper Weld Ass'y	1	
35	303 034	Bumper Weld Ass'y		1
36	Kit 303 040	Trough, Auger and Bearing Kit (includes Ref. 36 thru 41)	1	1
36	303 041	Trough Weld Ass'y	1	1
37	303 033	Auger Weld Ass'y Lower	1	1
38	69 009	Key 1/4" sq. x 1"	1	1
39	202 920	Bearing, Cast Flange and Collar	1	1
40	202 915	Ball Bearing with Collar	1	1
41	202 949	Flangette - 3 Hole	2	2
42	202 520	Bearing Plate	1	1
43	202 933	Spring (Holding Pawl)	1	1
44	202 891 X1	Pin 3/8 x 3 1/8	1	1
45	64 011	Washer 3/8 SAE	AR	AR
46	202 378	Washer Special	1	
47	64 018	Screw Flat Head 3/8 NC 3/4	1	
48	65 011	Cap Screw 1/2 NC x 1 3/4	1	1
49	65 002	Cap Screw 1/2 NC x 2	1	1
50	65 004	Washer 1/2 USS	8	8
51	65 003	Lock Washer 1/2	2	2
52	65 001	Nut 1/2 NC Hex	2	2
53	63 016	Truss Hd. Whiz Screw 5/16 NC x 1/2	AR	AR
54	63 009	Carr. Bolt 5/16 NC x 3/4	AR	AR
55	63 018	Carr. Bolt 5/16 NC x 1	3	3
56	63 010	Whiz Nut 5/16 NC	AR	AR
57	64 012	Cap Screw 3/8 NC x 3/4	AR	AR
58	64 009	Nut 3/8 NC Hex	AR	AR

AR - As Required

REAR PANEL AND CONTROLS

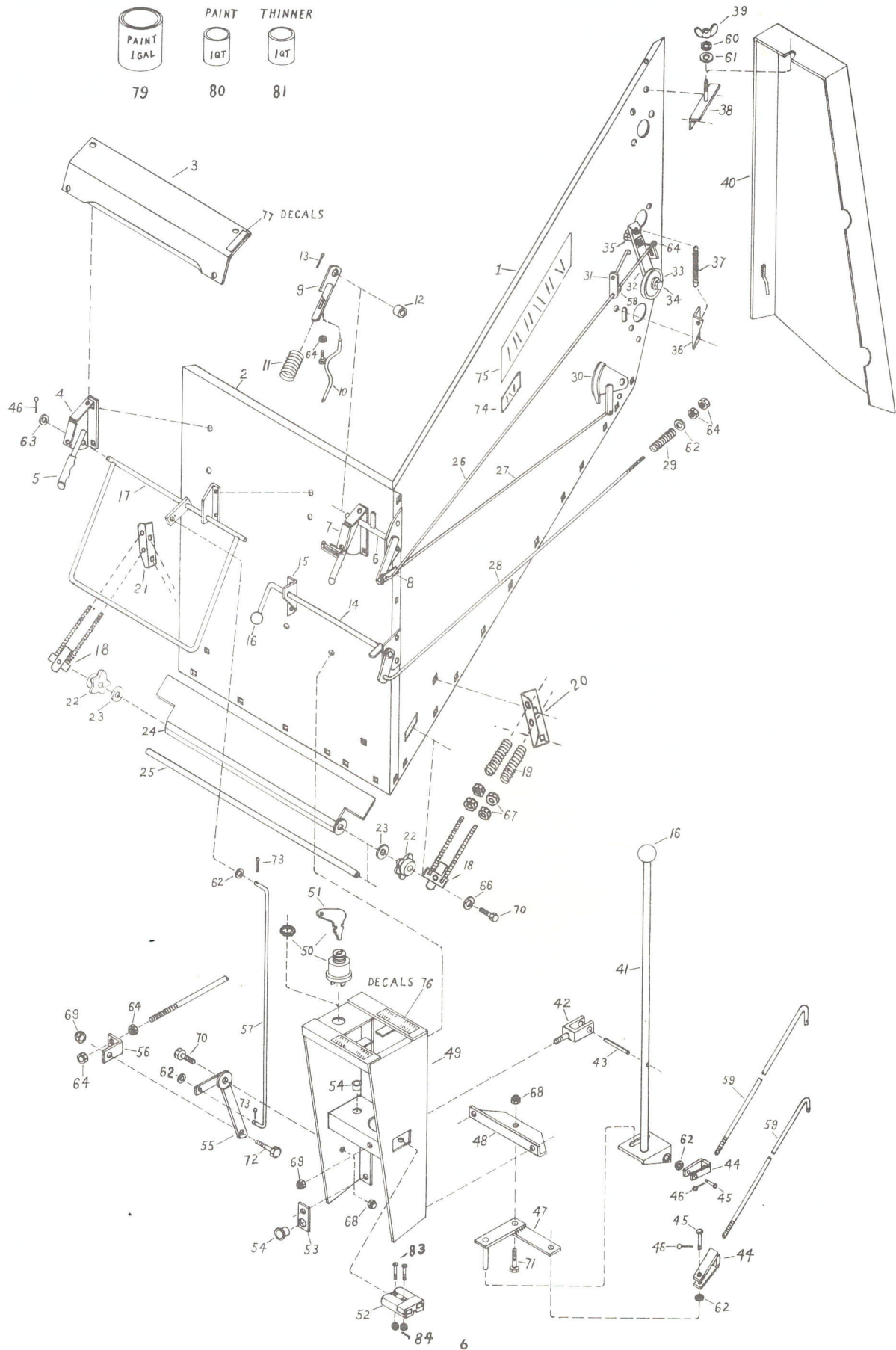
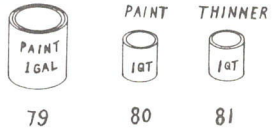

REAR PANEL AND CONTROLS

Ref. No.	Part No.	Description	Quantity Used	
			323	330
1	202 367 X1	Side Sheet R.H.	1	
1	202 521 X1	Side Sheet R.H.		1
2	202 523	Rear Panel	1	1
3	202 588	Dash	1	1
4	202 775 X1	Handle Weld A'ssy L.H.	1	1
5	202 913	Handle Grip	2	2
6	202 745 X1	Handle Weld Ass'y R.H.	1	1
7	202 821 X1	Quadrant Weld Ass'y	1	1
8	202 796	Clevis Weld Ass'y	1	1
9	202 787	Latch Weld Ass'y	1	1
10	202 825	Trigger Weld Ass'y	1	1
11	202 931	Spring	1	1
12	202 789	Spacer	1	1
13	61 003	Cotter Pin 1/8 x 1	1	1
14	202 481	Feeder Clutch Handle Weld Ass'y	1	1
15	202 458	Bracket	1	1
16	202 479	Knob	2	2
17	202 455	S.P. Clutch Handle Weld Ass'y	1	1
18	303 042	Tightener Bracket Weld Ass'y	2	2
19	202 503	Spring (Apron)	4	4
20	303 043	Bracket R.H.	1	1
21	303 044	Bracket L.H.	1	1
22	202 757	Apron Idler Sprocket	2	2
23	67 001	Washer 3/4 SAE	2	2
24	202 818	False End Weld Ass'y	1	1
25	202 734	Rear Apron Shaft	1	1
26	202 365	Rod, Beater Clutch	1	
26	202 506	Rod, Beater Clutch		1
27	202 364	Rod, Cam	1	
27	202 478	Rod, Cam		1
28	202 362	Rod, Feeder Clutch	1	
28	202 591	Rod, Feeder Clutch		1
29	202 950	Spring, Feeder Clutch Rod	1	1
30	202 727 X1	Cam	1	1
31	303 038	Baffle Pull Rod Weld Ass'y	1	1
32	202 490	Beater Clutch Arm	1	1
33	202 926	Belt Idler	1	1
34	65 011	Cap Screw 1/2 NC x 1 3/4	1	1
35	65 008	Jam Nut 1/2 NC Hex	1	1
36	202 502	Anchor, Spring	1	1
37	202 674	Spring, Beater Clutch	1	1
38	202 576	Shield Bracket	1	1
39	62 004	Wing Nut 1/4" NC	1	1
40	202 570	Shield - Weld Ass'y	1	1
41	202 452	Shifter - Weld Ass'y	1	1
42	202 443	Pivot Yoke, Shifter	1	1
43	61 005	Roll Pin 1/8" x 7/8"	1	1
44	202 896	Clevis	2	2
45	202 892	Clevis Pin 5/16" x 3/4"	2	2
46	61 001	Cotter Pin 1/8" x 3/4"	2	2
47	202 462	Shift Pivot - Weld Ass'y	1	1
48	202 461	Bracket	1	1
49	202 437	Control Box - Weld Ass'y	1	1
49	202 543	Cover - Control Box	1	1
	61 004	Self Tapping Screw - for above	2	2
50	202 954	Key Switch - with One Key	1	1
51	202 955	Key	AR	AR
52	202 960	Charger Receptacle - See Page 9 Ref. #19	1	1
53	202 585	Bracket	1	1
54	202 962	Grommet	2	2
55	202 448	S.P. Clutch Pivot	1	1

CONTINUED

AR - As Required

REAR PANEL AND CONTROLS

Ref. No.	Part No.	Description	Quantity Used	
			323	330
56	202 451	Angle	1	1
57	202 447	Rod — S.P. Clutch	1	1
58	202 956	Set Collar $\frac{3}{16}$	1	1
59	202 363	Rod, Shift	2	
59	202 590	Rod, Shift		2
60	62 006	Lock Washer $\frac{1}{4}$	1	1
61	62 007	Flat Washer $\frac{1}{4}$ USS	1	1
62	63 005	Flat Washer $\frac{5}{16}$ SAE	AR	AR
63	65 014	Flat Washer $\frac{1}{2}$ SAE	1	1
64	63 007	Nuts $\frac{5}{16}$ NC Hex	AR	AR
66	64 006	Lock Washer $\frac{3}{8}$	2	2
67	64 009	Nut $\frac{3}{8}$ NC Hex	8	8
68	64 002	Lock Nut $\frac{3}{8}$ NC	2	2
69	63 004	Lock Nut $\frac{5}{16}$ NC	2	2
70	64 003	Cap Screw $\frac{3}{8}$ NC x 1	3	3
71	64 001	Cap Screw $\frac{3}{8}$ NC x $1\frac{1}{4}$	1	1
72	63 003	Cap Screw $\frac{5}{16}$ NC x $\frac{3}{4}$	1	1
73	61 002	Cotter Pin $\frac{3}{32}$ x $\frac{5}{8}$	AR	AR
74/77	212 208	Decals, Full Set (323)	1	
74/77	212 209	Decals, Full Set (330)		1
74	212 210	Decal, "323"	2	
74	212 211	Decal, "330"		2
75	212 203	Decal, Weaverline	3	3
76	212 202	Decal, Gear Shift	1	1
77	212 201	Decal, Feed Rate	1	1
79	212 205	Paint, 1 Gallon	AR	AR
80	212 206	Paint, 1 Quart	AR	AR
81	212 207	Thinner, 1 Quart	AR	AR
83	61 012	Truss Hd. Mach. Screw #6 NC x 1	2	2
84	61 011	Nut #6 NC Hex	2	2

WIRES AND BATTERIES

1	202 400	Drawer Weld Ass'y	1	1
2	202 550	Drawer End R.H.	1	1
3	202 548	Drawer End L.H.	1	1
4	202 431	Roller	6	6
5	202 561	Spring	1	1
6	202 560	Latch	1	1
7	202 559	Battery Hold Down	1	1
8	202 558	Threaded Rod $\frac{1}{4}$ " NC	1	1
9	202 966	Battery 6 Volt	4	4
10	202 598	Wire — Battery to Battery	1	1
11	202 597	Wire — Battery to Battery	2	2
12	202 568	Wire — Solenoid to Battery	1	1
13	202 599	Wire — Motor to Battery	1	1
14	202 595	Wire — Motor to Solenoid	1	1
15	202 376	Wire Ass'y — Includes Black, Yellow and Contact	1	
15	202 592	Wire Ass'y — Includes Black, Yellow and Contact		1
16	202 374	Wire — Keyswitch to Solenoid	1	
16	202 566	Wire — Keyswitch to Solenoid		1
17	202 377	Wire — Charger Receptacle to Solenoid and Contact	1	
17	202 596	Wire — Charger Receptacle to Solenoid and Contact		1
18	202 405	Solenoid 24 Volt (Special)	1	1
19	202 960	Charge Receptacle (Plug)	1	1
20	202 975	Contact	2	2
21	202 979	Housing A'ssy	1	1
22	62 008	Cap Screw $\frac{1}{4}$ NC x $\frac{3}{8}$	6	6
23	202 954	Keyswitch — with One Key	1	1

CONTINUED

AR — As Required

TRACTION DRIVE UNIT

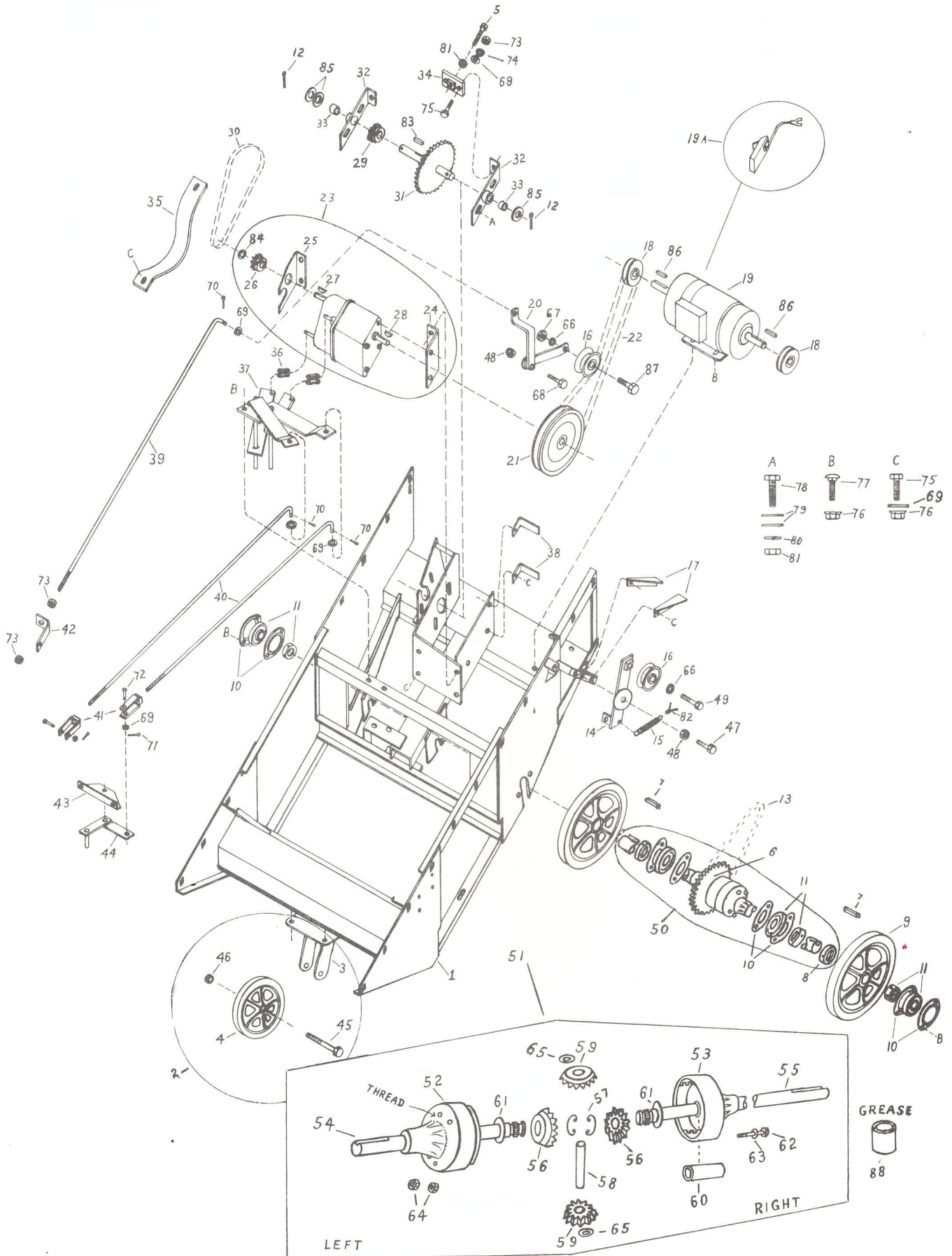

WIRES AND BATTERIES

Ref. No.	Part No.	Description	Quantity Used	
			323	330
24	62 012	Flat Washer 1/4 SAE	7	7
25	62 002	Whiz Nut 1/4 NC	12	12
26	64 012	Cap Screw 3/8 NC x 3/4	1	1
27	64 005	Flat Washer 3/8 USS	2	2
28	64 006	Lock Washer 3/8	1	1
29	64 009	Nut 3/8 NC Hex	1	1
30	202 557	Flat Washer 1/4 I.D. x 23/16 O.D.	1	1
31	62 006	Lock Washer 1/4	1	1
32	62 004	Wing Nut 1/4 NC	1	1
33	61 001	Cotter Pin 1/8 x 3/4	1	1
34	62 017	Mach. Screw, Round Head 1/4 NC x 1 1/4	6	6
35	202 957	Terminal 5/16" Stud — 8 ga. Wire	AR	AR
36	202 984	Clamp — for Battery Post with Damaged Stud	AR	AR
37	63 007	Nut 5/16 NC Hex	8	8
38	212 212	Aerosal Spray, Corrosion Preventive	AR	AR
39	212 213	Battery Terminal Protector, Bag of 8	1	1

TRACTION DRIVE UNIT

1	303 045	Undercarriage Weld Ass'y	1	
1	303 050	Undercarriage Weld Ass'y		1
2	202 372	Caster Wheel Ass'y (Includes 3 and 4)	1	
2	202 901	Caster Wheel Ass'y (Includes 3 and 4)		1
3	202 380	Caster Fork Ass'y	1	
3	202 676	Caster Fork Ass'y		1
4	202 373	Caster Wheel 6"	1	
4	202 677	Caster Wheel 8"		1
5	64 010	Set Screw 3/8 NC x 2	1	1
6	303 103	Sprocket	1	1
7	69 003	Key 1/4 Sq. x 2 1/2	2	2
8	202 697	Shaft Collar 1"	1	1
9	202 900	Wheel	2	2
10	202 916	Flangette 2 Hole	8	8
11	202 915	Ball Bearing 1" with Collar	4	4
12	61 003	Cotter Pin 1/8 x 1	2	2
13	202 840	Chain #40 — 70 Pitches	1	1
14	202 487	Feeder Clutch Weld Ass'y	1	1
15	202 933	Spring (Feeder Clutch Return)	1	1
16	202 926	Belt Idler	2	2
17	202 528	Belt Guide (Feeder)	2	2
18	202 584	Sheave — 2 3/4 O.D.	2	2
19	202 600	Motor 24 Volt D.C.	1	1
19	202 600 R	Motor 24 Volt D.C. Factory Rebuilt	AR	AR
19 (A)	202 980	Brushes (for above Motor)	4	4
20	202 473	S.P. Clutch Weld Ass'y	1	1
21	202 445	Sheave 8 1/2 O.D. 5/8 Bore	1	1
22	202 407	Belt 4L 470	1	1
23	202 669 SG	Transmission — Complete, Steel Gear Type	1	1
23	202 669 SGR	Transmission — Rebuilt Complete, Steel Gear Type	AR	AR
24	202 620	Mounting Bracket Input End	1	1
25	202 618	Mounting Bracket Output End	1	1
26	202 619	Sprocket 8 Teeth	1	1
27	69 002	Woodruff Key #4 (3/32 x 5/8)	1	1
28	69 001	Woodruff Key #9 (3/16 x 3/4)	1	1
29	202 696 H	Sprocket — 11 Teeth Hardened	1	1
30	202 583	Chain #41 — 65 Pitches	1	1
31	202 419	Sprocket and Shaft Weld Ass'y	1	1
32	202 411	Plate-Tightener with Bushing	2	2
33	202 535	Bushing Oilite	2	2

CONTINUED

AR — As Required

TRACTION DRIVE UNIT

Ref. No.	Part No.	Description	Quantity Used	
			323	330
34	202 526	Block Tightener	1	1
35	202 581	Chainguard	1	1
36	202 940	Connector Link #40	2	2
37	202 467	Shift Pivot Arms Ass'y	1	1
38	202 538	Belt Guide (S.P.)	2	2
39	202 361	Rod (S.P. Clutch)	1	
39	202 460	Rod (S.P. Clutch)		1
40	202 363	Rod (Shift)	2	
40	202 590	Rod (Shift)		2
41	202 896	Clevis Weld Ass'y	2	2
42	202 451	Angle	1	1
43	202 461	Bracket	1	1
44	202 462	Shift Pivot Weld Ass'y	1	1
45	65 018	Cap Screw 1/2 NC x 3 1/2	1	1
46	65 019	Lock Nut 1/2 NC	1	1
47	64 001	Cap Screw 3/8 NC x 1 1/4	1	1
48	64 002	Lock Nut 3/8 NC	2	2
49	65 011	Cap Screw 1/2 NC x 1 3/4	1	1
50	303 101	Differential, Complete with Sprocket, 2 Bearing and Collar	1	1
51	303 102	Differential Assembly	1	1
52	303 105	Housing Ass'y, Left (Threaded Holes)	1	1
53	303 106	Housing Ass'y, Right	1	1
54	303 108	Axle, Left, Short	1	1
55	303 109	Axle, Right, Long	1	1
56	303 111	Bevel Gear, for Axle	2	2
57	303 107	Snap Ring	2	2
58	303 112	Pin	1	1
59	303 110	Pinion Gear	2	2
60	303 104	Bushing, Bronze	2	2
61	303 113	Washer, Hardened 1"	2	2
62	303 114 X1	Cap Screw 5/16 NC x 4 Grade 8 (Special)	4	4
63	303 115	Flat Washer 5/16	4	4
64	63 007	Nuts 5/16 NC (2 per Bolt for Locking)	8	8
65	303 116	Washer, Hardened 5/8	2	2
66	65 016	Lock Washer, 1/2 Internal Teeth	1	1
67	65 001	Nut 1/2 NC Hex	AR	AR
68	64 017	Cap Screw 3/8 NC x 1 3/4	1	1
69	63 005	Flat Washer 5/16 SAE	AR	AR
70	61 002	Cotter Pin 3/32 x 5/8	AR	AR
71	61 001	Cotter Pin 1/8 x 3/4	2	2
72	202 892	Clevis Pin 5/16 x 3/4	2	2
73	63 007	Nut 5/16 NC Hex	AR	AR
74	63 006	Lock Washer 5/16	2	2
75	63 003	Cap Screw 5/16 NC x 3/4	AR	AR
76	63 010	Whiz Nut 5/16 NC	AR	AR
77	63 009	Carriage Bolt 5/16 NC x 3/4	AR	AR
78	64 003	Cap Screw 3/8 NC x 1	AR	AR
79	64 005	Flat Washer 3/8 USS	AR	AR
80	64 006	Lock Washer 3/8	AR	AR
81	64 009	Nut 3/8 NC Hex	AR	AR
82	61 007	Cotter Pin, 3/16 x 3/4	1	1
83	69 006	Key — 3/16 Sq. x 1 3/8	1	1
84	202 617	Snap Ring	1	1
85	67 001	Flat Washer 3/4 SAE	AR	AR
85	67 002	Flat Washer 3/4 Veri-thin	AR	AR
86	69 006	Key 3/16 Sq. x 1 3/8	2	2
87	65 002	Cap Screw 1/2 NC x 2	1	1
88	212 114	Lubricant, Differential, Special	AR	AR

AR — As Required

Weaverline Corporation Churchtown, Pa. 17555